

DHL300 CNC Loader

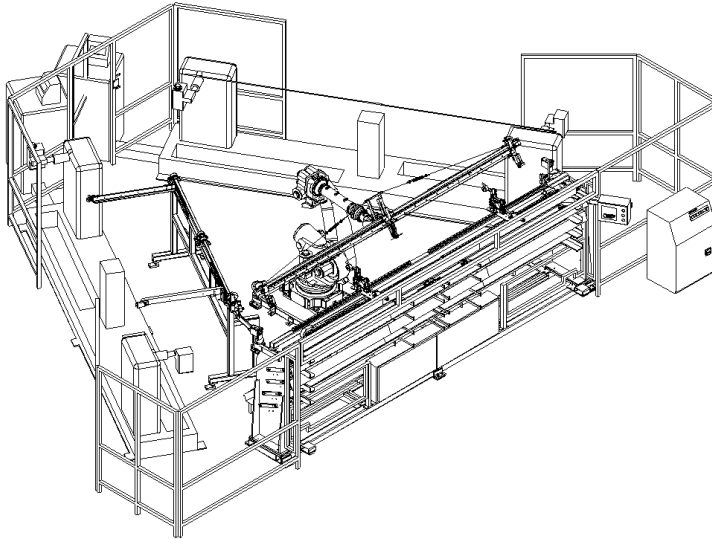

Description

The DHL300 CNC Loader has been developed for long tube bending applications. Extremely versatile, the DHL300 has a Multi-level Tube Feeder System which allows the CNC Bender the flexibility to bend different tubes without changeover. Its flexible design can accommodate a wide variety of tube diameters and lengths. Combined with increased tube capacity and the ability to load multiple CNC benders at one time, substantial increases in productivity can be obtained over traditional loading systems.

Applications

- Automotive Brake & Fuel Lines
- Automotive Air Conditioning Lines

Standard Features

- Dual CNC Tube Loading Capability
- Multi-level/Tube Bulk Feeder
- Centralized Robotic Tube Load and Singulation System
- Quick Tube Length Adjustment
- Quick Tube Diameter Adjustment
- Tube Blockage Verification
- Reject Stage
- Advanced Control System Capable of Storing up to 100 Different Tube Configurations
- Colour Touch Screen HMI
- Error Messaging System

Options Available

- Tape Applicator
- Tube Blockage Verification
- Mechanical Inspection of Tube End Forms
- Vision Inspection of Tube End Forms
- Fallout Racks
- Cell Guarding

Specifications

| | |
|----------------------|------------------------------------|
| Diameter Range | 3/16" to 1/2" |
| Length Range | 48" to 200" |
| Tube Capacity (Max.) | 200 Pcs. (3/16 Dia. with Fittings) |
| Electrical* | 120/230 VAC, 60/50 Hz |
| Pneumatic | 80 PSI |

* Contact CMP for other power options available

Contact CMP directly for more information beyond the scope of this document



CMP Automation Inc.

229 Boida Avenue, Ayr, Ontario, Canada, N0B 1E0
 Tel: (519) 740-6035 Fax (519) 622-5894
 Email: salescanada@cmpautomation.ca
 Web: www.cmpautomation.ca