

SHL200 CNC Loader

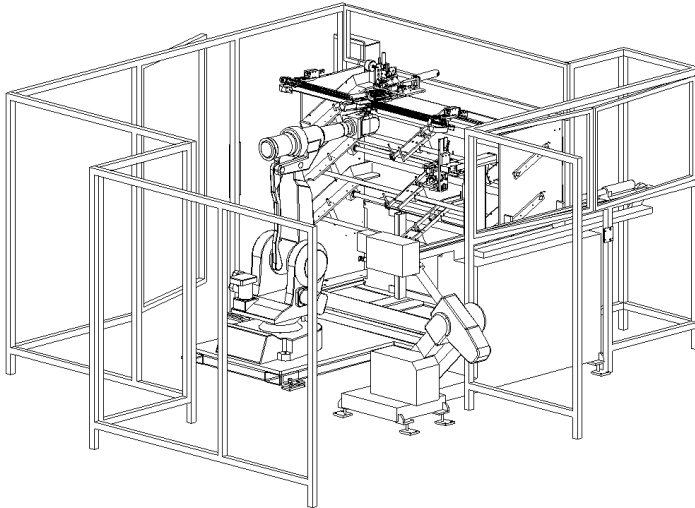

Description

The SHL200 CNC Loader is one of the most versatile CNC loaders on the market. The Multi-level Tube Feeder System gives the CNC the ability to bend different tube types without feeder changeover. Its flexible design can accommodate a wide variety of tube diameters and lengths. Combined with increased tube capacity, significant productivity increases can be obtained over traditional loading systems.

Applications

- Automotive Brake & Fuel Lines
- Automotive Air Conditioning Lines
- Automotive Seating Components
- Furniture Components

Standard Features

- Multi-level/Tube Bulk Feeder
- Centralized Robotic Tube Load and Singulation System
- Quick Tube Length Adjustment
- Quick Tube Diameter Adjustment
- Tube Blockage Verification
- Reject Stage
- Advanced Control System Capable of Storing up to 100 Different Tube Configurations
- Colour Touch Screen HMI
- Error Messaging System

Options Available

- Tape Applicator
- Tube Blockage Verification
- Mechanical Inspection of Tube End Forms
- Vision Inspection of Tube End Forms
- Fallout Rack
- Cell Guarding

Specifications

Diameter Range	3/16" to 1/2"
Length Range	12" to 72"
Tube Capacity (Max.)	150 Pcs. (3/16 Dia. w/ Fittings)
Electrical*	120/230 VAC, 60/50 Hz
Pneumatic	80 PSI

* Contact CMP for other power options available

Contact CMP directly for more information beyond the scope of this document



CMP Automation Inc.

229 Boida Avenue, Ayr, Ontario, Canada, N0B 1E0
 Tel: (519) 740-6035 Fax (519) 622-5894
 Email: salescanada@cmpautomation.ca
 Web: www.cmpautomation.ca