

## SHU100 CNC Unloader

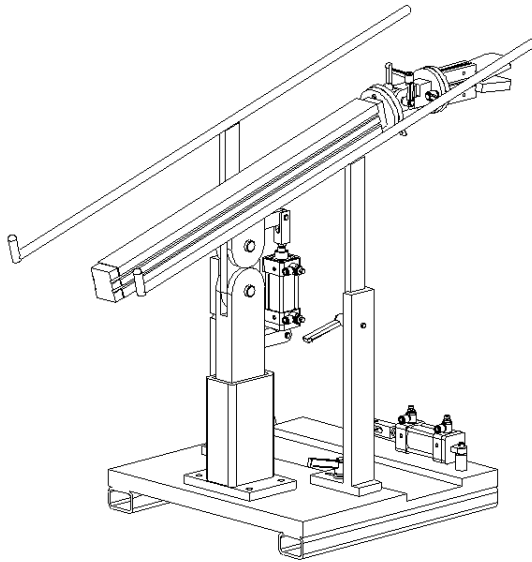

### Description

The SHU100 CNC Unloader offers a flexible cost effective solution to CNC unloading. Offering adjustability along five axes, the SHU100 CNC Unloader is capable of unloading almost any contour you choose to bend. This Unloader is ideally suited for use with the SHL050 and SHL100 CNC Loaders.

### Applications

- Automotive Brake & Fuel Lines
- Automotive Air Conditioning Lines
- Furniture Components
- Medical Equipment

### Standard Features

- Multi-Axis adjustability
- Tool-less Adjustment of Arm and Rails
- Compact Design

### Options Available

- Machine Controls

### Specifications

Diameter Range	3/16" to 1/2"
Length Range	10" to 48"
Pneumatic	80 PSI

*Contact CMP directly for more information beyond the scope of this document*



#### **CMP Automation Inc.**

229 Boida Avenue, Ayr, Ontario, Canada, N0B 1E0  
 Tel: (519) 740-6035 Fax (519) 622-5894  
 Email: salescanada@cmpautomation.ca  
 Web: www.cmpautomation.ca